



# Graham Appearance Commission Meeting Agenda

February 12th,  
2026

6:00pm Graham  
City Hall

1. Call Meeting to Order
2. Pledge of Allegiance
3. Invocation
4. Approval of minutes from the January, 2026 meeting
5. **Items of Discussion**

### Business Beautification Grants

**5a.** 202 N Main Street

### Future Business:

**5b.** 2026 Goals, Ideas, and Calendar- Further Discussion (if needed)

**5c.** Local Business Involvement – Renee Russell

**5d.** Residential/Business Appearance Awards – Further Discussion

**5e.** Arbor Day – Brandy McCandless

6. City Council Updates

7. Staff Updates

8. Adjournment



## MINUTES

### Graham Appearance Commission Meeting

January 5<sup>th</sup>, 2026

City Hall Council Chambers

#### In Attendance:

**Chair Zipporah Clark- Baldwin, Vice Chair Cheryl Ray, Bernadette Konzelmann, Clell Britt and Emily O'Dell.**

**Staff: Cameron West and Jonathan Buckley.**

- **Meeting was called to order at 6:09pm by Vice Chair Cheryl Ray, followed by the Pledge of Allegiance, and a moment of silence.**
- **Approval of the November and December, 2025 Meeting Minutes**
  - Ms. Konzelmann moved to approve the minutes as presented, Mr. Britt seconded. All voted aye.
- **Downtown Window Decorations**
  - Chair Clark-Baldwin introduced and summarized the Window Decoration contest.
  - Each member gave their rankings and Jonathan Buckley tallied the top contenders.
  - The commission elected first place to Whits, second place to Things Above and third place to Skid's II.
- **Business Beautification Grants**
  - Jonathan Buckley introduced applications for the new 2025 grants.
  - Victoria Beamer spoke on behalf of the Geriatric Clinic submittal.
  - Adam Miller spoke on behalf of the Frank's Jewelry submittal.
  - Vice Chair Ray made the motion to approve the Geriatric Clinic submittal at its specific funding amount and table the Frank's Jewelry submittal for next month's consideration, seconded by Mr. Britt. All in favor.
- **Banner Update**
  - Jonathan Buckley and Cameron West provided a brief explanation of the pending revision to the City's logo and how this will impact the banner decorations.
- **2026 Calendar Planning**
  - The commission looked at the year ahead and discussed multiple ideas for 2026.
  - These included improved local business involvement, Arbor Day planning and litter cleanups, seasonal voting for the Residential and Business Appearance Awards and more structured planning for autumn decorations.
  - The discussion led to overall agreement and the Commission determined to focus on marketing, outreach and Arbor Day planning the following month.
- **Council**
  - Mayor Chelsea Dickey introduced herself as liaison and proposed improving

neighborhood engagement, landscaping and mural projects.

- **Staff**
  - Cameron West and Jonathan Buckley provided no other updates.
- **Meeting adjourned**
  - Chair Clark-Baldwin motioned for the meeting to be adjourned. Seconded by Vice Chair Ray. All members voted aye. Meeting adjourned at 7:24pm

**Minutes Submitted by Jonathan Buckley**

**January 13<sup>th</sup>, 2026**



## 2025-2026 Business Beautification Grant Program Application

Property Information <b>(Please type or print clearly)</b>	Applicant Information <b>(Please type or print clearly)</b>
Street Address: 202 North Main Street	Name: Adam Miller
Tax Parcel ID#: 8884155080	Phone Number: 336-263-1200
Owner's Name: Adam Miller	Email: franksjlry@gmail.com
Use of Building: Retail Store	Relationship to Property <i>(check one)</i> : Property Owner <input checked="" type="checkbox"/> Tenant/Business Owner <input type="checkbox"/>
Business Name <i>(if applicable)</i> : Frank's Jewelry	

### Description of Proposed Improvement

Write a brief description below and attach 1) an existing photo of the project area; 2) a drawing, sketch or picture of the proposed improvement. **(Please type or print clearly)**

The proposed improvement is new front signage that will be well lit and easily seen from Main Street. We are currently reviewing options for both replacement of our current front facing sign as well as the upgrade of our current sign and the addition of a side facing round illuminated sign. Considerations from existing trees planted by the city, as well as obstructed views of current signage due to the addition of city wayfinding signage are being considered in this process. Please direct any questions to Adam Miller at franksjlry@gmail.com. A few proposals from two companies have been submitted, and a third company has not yet provided a price estimate as of December 29th, 2025.

Total Estimated Cost *(lowest bid quote)*: \$ 4200.00 - 7600.00 depending on scope of work.

***Attach at least two itemized cost estimates from vendors/contractors for proposed work.***



# 2025-2026 Business Beautification Grant Program Application

I [have  / have not If you answered "Have", please state from what source, amount and date of award.

## Checklist for a Complete Application

- I have read the City of Graham *Business Beautification Grant Program* overview and fully understand the agreement.
- I have met with the City Building Inspector and  
My project [does  / does not - The owner's written and signed permission is attached, if applicant is not owner.  
 Not applicable
- An existing picture of the project area and a drawing, sketch and/or picture of the proposed improvement are/is attached.
- At least two itemized project cost estimates are attached.
- If located in the Graham Historic District, I have received Certificate of Appropriateness (COA) approval for the work submitted in this application prior to the Appearance Commission meeting in which these grant funds will be awarded.
- I understand in order to receive reimbursement, my project must be completed, inspected, and approved by the City's Inspections and Planning Departments.
- I understand in order to receive reimbursement all paid receipts must be submitted to the planning department.

AM  
Initials I understand that the City of Graham *Business Beautification Grant Program* must be used in the manner described in this application, with all of the work herein described prior to the reimbursement of any funds.

AM  
Initials I understand the application must be approved by the Graham Appearance Commission prior to commencement of any project.

AM  
Initials I understand that failure to comply with the approved application may result in a forfeiture of all grant funds.

AM  
Initials I understand that failure to complete the project by **May 1, 2026** will result in the forfeiture of all grant funds. A request for an extension filed in writing prior to the deadline may result in an extension until no later than June 1, 2026.

Adam Miller (electronic signature) 12/29/2025

**Applicant Signature** **Date**

# FRANK'S JEWELRY/ CABINET SIGN OPTION A

INSTALL ADDRESS:  
202 N Main St, Graham,  
NC 27253, USA



MOCKUP BY DAY



MOCKUP BY NIGHT



MEASUREMENTS



SIDE VIEW

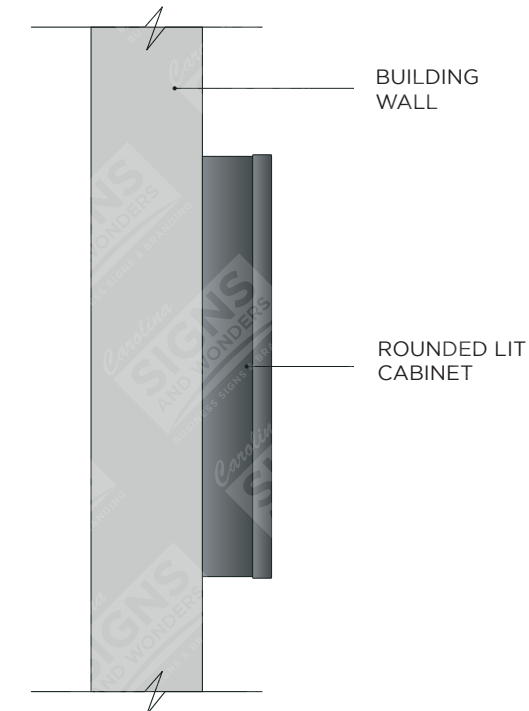

ORDER NUMBER: 103956

## DESCRIPTION:

Rounded Lit Cabinet, with polycarb face.

## DIMENSIONS:

10' - 1 7/8" (W) x 3' - 1 1/8" (H)  
31.41 SQ FT

## FACE COLOR:

- BLACK
- WHITE

## CONTACT INFO:

jeff@ncsign.com  
803-686-3901  
ncsign.com

**FRANK'S JEWELRY/ CABINET SIGN**  
**OPTION B**

MOCKUP BY DAY



MOCKUP BY NIGHT



MEASUREMENTS



SIDE VIEW

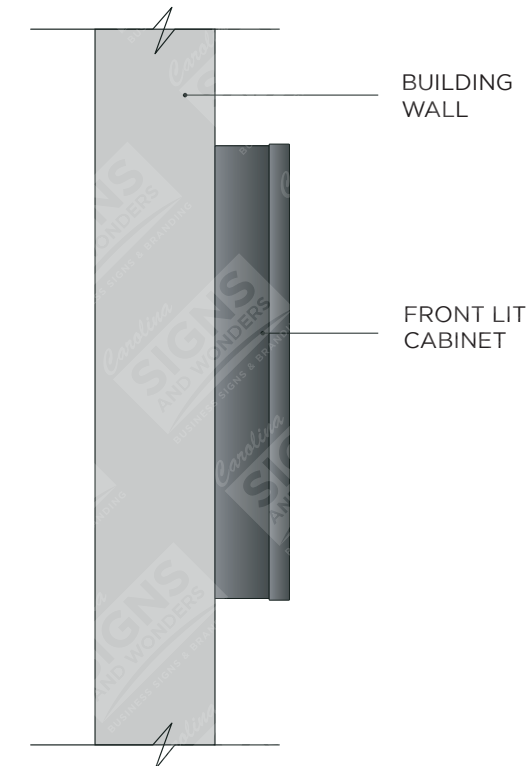

ORDER NUMBER: 103956

**DESCRIPTION:**

Front Lit Cabinet, with polycarb face.

**DIMENSIONS:**

10' - 8 1/8" (W) x 3' - 1 3/16" (H)  
 33 SQ FT

**FACE COLOR:**

- BLACK
- WHITE

**CONTACT INFO:**

jeff@ncsign.com  
 803-686-3901  
 ncsign.com

**FRANK'S JEWELRY/ CABINET SIGN**  
**OPTION C**



MOCKUP BY DAY



MOCKUP BY NIGHT



MEASUREMENTS

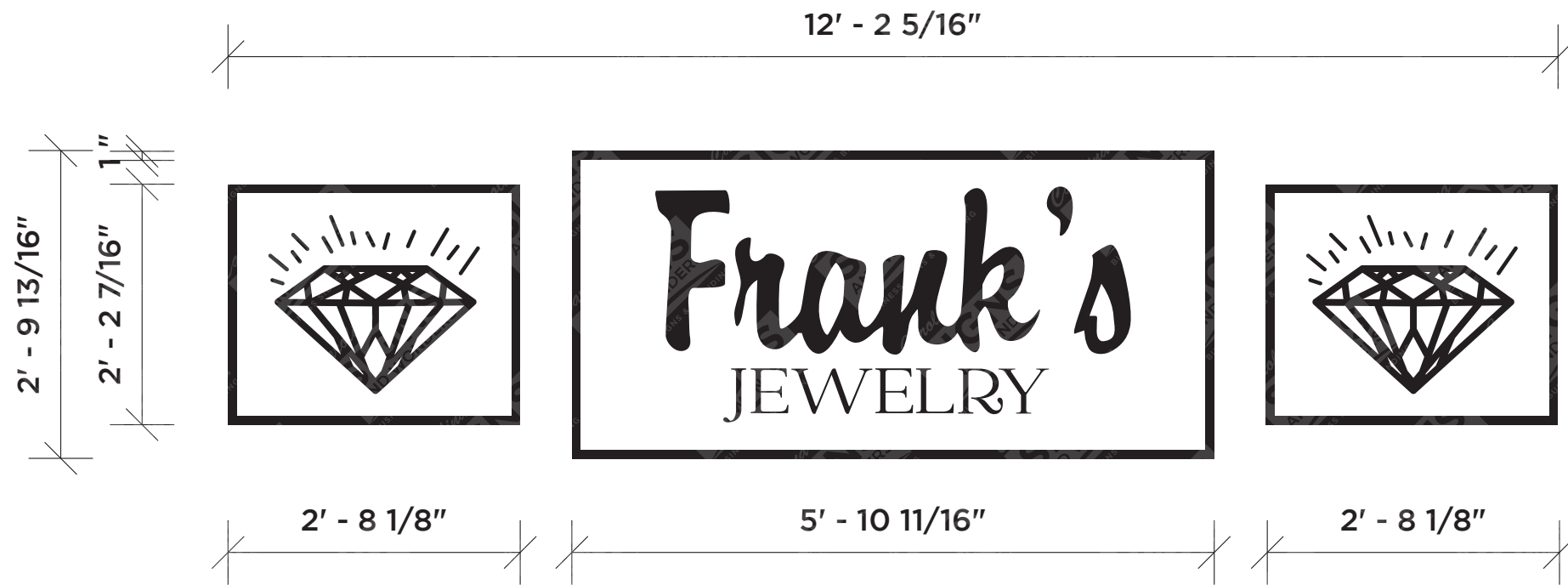

SIDE VIEW

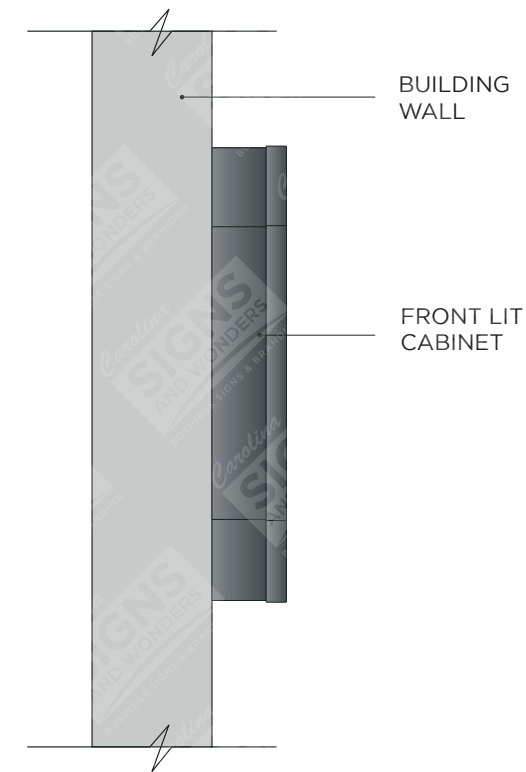

ORDER NUMBER: 103956

DESCRIPTION:

Front Lit Cabinet, with polycarb face.

DIMENSIONS:

12' - 2 5/16" (W) x 2' - 9 13/16" (H)  
 34.38 SQ FT

FACE COLOR:

- BLACK
- WHITE

CONTACT INFO:

jeff@ncsign.com  
 803-686-3901  
 ncsign.com

# FRANK'S JEWELRY/ CHANNEL LETTERS

## OPTION D

MOCKUP BY DAY

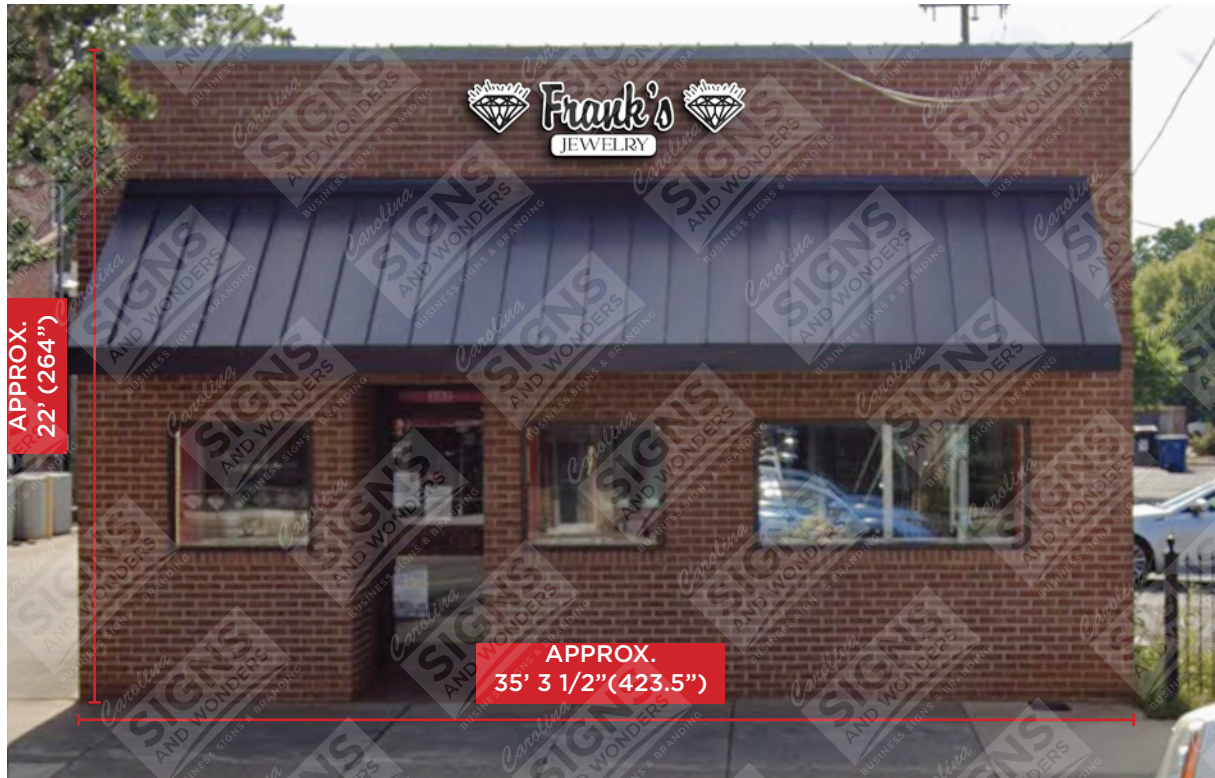

MOCKUP BY NIGHT



MEASUREMENTS



SIDE VIEW

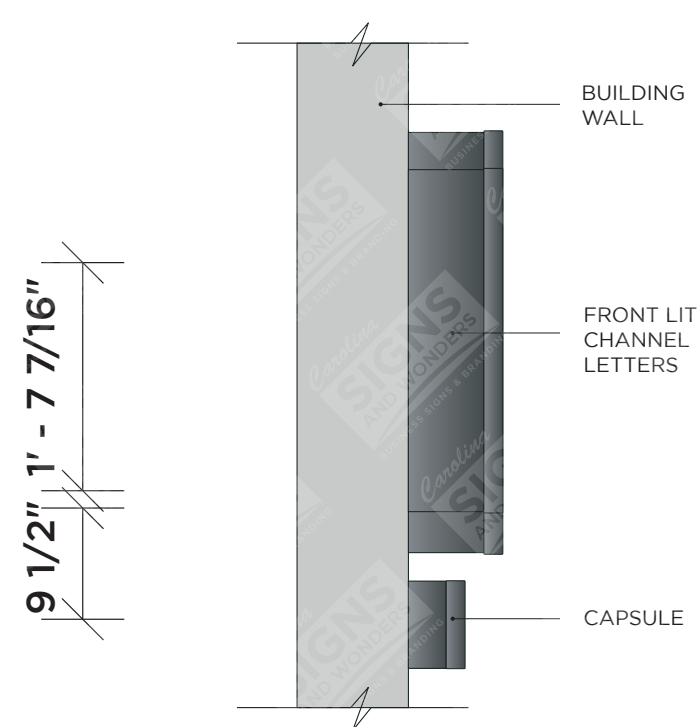

ORDER NUMBER: 103956

### DESCRIPTION:

Front Lit Channel Letters with a capsule for smaller text, flush mounted.

### DIMENSIONS:

9' - 4"(W) x 2' - 7 5/16"(H)  
24.28 SQ FT

### FACE COLOR:

- BLACK
- WHITE

### CONTACT INFO:

jeff@ncsign.com  
803-686-3901  
ncsign.com

- **Any changes from the above specifications may result in additional cost to be paid by purchaser and may result in additional time for completion.**
- Signing this document shows that the customer has seen the artwork and has approved the artwork. Any changes to the artwork after production will be the responsibility of the customer to cover the cost of the changes and materials.
- This contract is for custom work and accordingly cannot be cancelled once accepted.
- Artwork Specific existing logo artwork shall be provided by others in digital format, ready for output unless otherwise specified, free of encumbrances or copyrights. Purchaser agrees to indemnify Carolina Signs and Wonders (CSAW) for any use of encumbered or copyrighted artwork provided to CSAW.
- Permitting, Engineering and Owner Approval If requested by Purchaser, CSAW agrees to procure permits.
- Permits and permit acquisition are not a part of this contract unless specified as a separate line item.
- Structural engineering calculations are not a part of this contract unless specified as a separate line item.
- Purchaser is required to procure authorization and approval for all signage by the property Owner.
- All signage is subject to city and municipality codes and ordinance requirements and therefore the estimate may be subject to change.
- CSAW will not be liable or responsible for any disputes with the Owner or City.
- Installation Purchaser is responsible to insure that the installation site is free and clear of all obstructions and that installation equipment can readily access the area of installation without encumbrance.

- CSAW Signs cannot be held responsible for any damage to landscape, plantings, or other obstructions during performance of installation or service work unless detailed in this proposal.
- Quoted installation charges are subject to change due to unforeseeable obstructions or hindrances.
- CSAW Signs is not responsible for cost or repairs due to damage by others.
- Electrical Connections Purchaser must ensure that a licensed electrician will provide an electrical connection within five feet of signage site before CSAW installers arrive. If no electrical power is available at time of installation, the purchaser will be responsible for having a licensed electrician complete the wiring from the power source to the sign.
- Renderings and mockups may differ slightly, therefore, it is the responsibility of the customer to relay any questions about the drawing to CSAW.
- Acceptance of this estimate (written or verbal) acknowledges these terms.
- Payments made with a credit card will have a 3% service fee added to cover processing charges.
- We prefer ACH payments.

**Signed:**

---

**Date:**

---

---

**CONTACT INFO:**

jeff@ncsign.com

803-686-3901

ncsign.com



RE:  
Company Name: \_\_\_\_\_  
Street: \_\_\_\_\_  
City: \_\_\_\_\_ State: \_\_\_\_ Zip Code: \_\_\_\_\_

Date: \_\_\_\_\_

AUTHORIZATION LETTER FOR EXTERIOR SIGN/APPLY FOR SIGN PERMIT

Dear Sir/Madam:

I am the Property Manager/Owner for the above referenced property. \_\_\_\_\_ plans have been reviewed and approved. \_\_\_\_\_ will be handling the sign construction and \_\_\_\_\_ will handle installation.

Any questions, please contact me via the information provided below.

Sincerely,

\_\_\_\_\_  
Printed

\_\_\_\_\_  
Signature

\_\_\_\_\_  
Date

\_\_\_\_\_  
Email

Street: \_\_\_\_\_ City: \_\_\_\_\_ State: \_\_\_\_\_ Zip Code: \_\_\_\_\_ County: \_\_\_\_\_  
Address

(\_\_\_\_) \_\_\_\_ - \_\_\_\_\_ (work)  
Phone

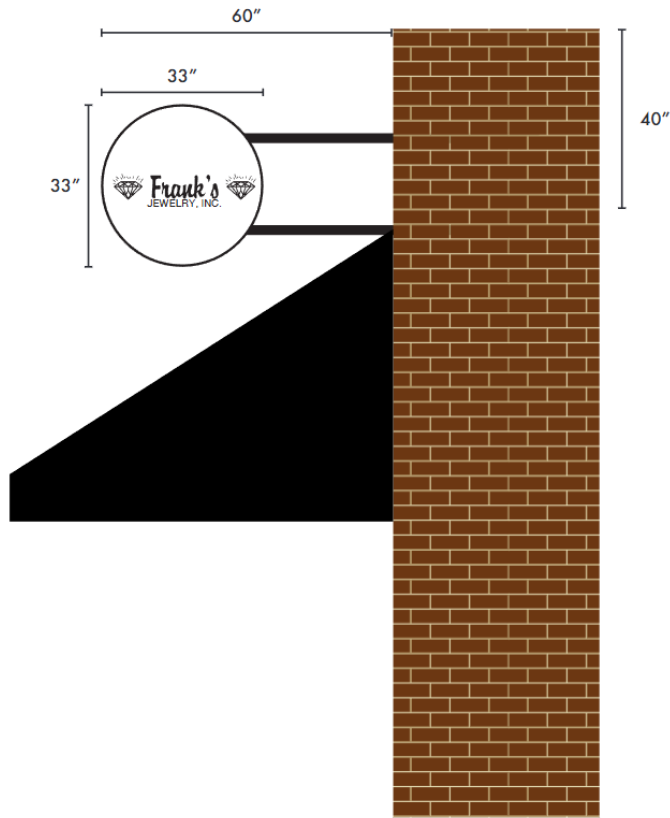

CURRENT:



<p>CUSTOMER: Franks Jewlery</p>	<p>JOB NUMBER: 149035</p>	<p>DETAILS: Blade Sign - Double Sided 33"w x 33"h 7.56 sf</p>	<p>SALES REP: Bobby Dunson</p>	<p>The colors you see are only representations of the final product. If you need to see the exact colors, please let us know. The reproduction or duplication of the drawings without the permission of TRIAD Signs is strictly prohibited under applicable copyright laws. All artwork appearing on this proof are property of Triad Signs until payment is received. I have read the above statement and approve this order. I understand that TRIAD Signs is not responsible for content or typographical errors after final approval is received.</p>
<p>INSTALL ADDRESS: 202 N Main St • Graham, NC 27253</p>	<p>PROOF DATE: 12/23/2025</p>		<p>DESIGNER: Arien</p>	

# Quote No. 12324

December 19, 2025

Page 1 of 2



**Customer** Frank's Jewelry

**Reference** Greensborro - Graham - Exterior - rectangle cabinet

**Bill to**

Frank's Jewelry  
Adam Miller  
202 N Main St  
Graham, NC 27253, NC 27253  
US  
T: 336-226-4553  
Email: franksjlry@gmail.com

**Ship to**

Frank's Jewelry  
Adam Miller  
202 N Main St  
Graham, NC 27253, NC 27253  
US  
T: 336-226-4553  
Email: franksjlry@gmail.com

<b>Valid Until</b>	01/18/2026	<b>Revision Date</b>	12/19/2025	<b>Lead Time</b>	7 - 8 weeks	<b>SR</b>	Jeff Lancashire
<b>F.O.B.</b>	N/A	<b>Revision No</b>		<b>Ship Method</b>		<b>PM</b>	Jeff Lancashire
<b>Terms</b>	50% deposit, 50% at completion						

No.	Item	Description
1.	Technical Site Survey	Technical Survey
2.	Permit Process and Acquisitions	Permit Process and Acquisitions In Municipality of Project Additional fees added after acquisition of sign permits
3.	Sign Production	Frank's Jewelry- Wall sign One wall sign led lit with opaque graphics approx3'1" x 10'8" x6"
4.	Installation	Frank's Jewelry- Wall sign One wall sign led lit with opaque graphics approx3'1" x 10'8" x6"

This quote is based on the information provided. If new information or changes are made after the quote has been provided, the prices may change accordingly.

Subtotal	7,352.08
Sales Tax (6.75 %)	268.52
<b>Total</b>	<b>7,620.60</b>

**Quote Valid Until: January 18, 2026**

By signing below, I approve and authorize this quote and acknowledge that I have read and agree to the attached terms and conditions.

Submitted by _____	Date _____	Approved by _____	Date _____
		Print Name _____	

continued on next page

# Quote No. 12324

December 19, 2025

Page 2 of 2



**Customer** Frank's Jewelry

**Reference** Greensborro - Graham - Exterior - rectangle cabinet

---

## Conditions

---

Thank you for considering Carolina Signs and Wonders (CSAW) for your sign needs. These Terms and Conditions shall govern our relationship throughout the length of the project. The Project, as used herein, shall mean the work contracted for by the customer ("you"), as described in detail in the Quote and Proof(s) that CSAW has or will provide(d) to you (the "Project"). Please review the Quote and Proof(s) to ensure all items are correct including colours, text, materials, size, quantity, spelling, punctuation, etc. Our work on the project will commence once we receive approval of the estimate and the required deposit described below. During the project, your approval of the Proof(s) will be required as necessary for the continuation and subsequent completion of the project.

- 1) Payment terms: 50% non-refundable deposit is required to begin project with the balance due upon completion. 100% payment required on orders \$500 paid for with credit card.
- 2) If this estimate is based on customer providing electronic copy of design file and the design file is not provided, additional charges will be incurred to recreate design. Changes to the design in excess of the quoted design services of the project, either in the number of changes or in scope, will result in additional charges over and above the original estimate.
- 3) Full payment is due upon completion of the job. A 15% late fee will be added to all invoices over 30 days each month until the balance is fully paid.
- 4) Any installation costs quoted are based on optimum conditions at the site, readiness of the walls or surfaces, the grounds, and other areas where the sign may be installed, as well as the description provided by the client. Additional charges will apply based on unexpected or unknown factors during the installation process.
- 5) All signs and related products described above are the property of CSAW until all money's owned under this agreement are paid in full and client will provide access to said signs if payment is not made in full when due. Client agrees to pay all attorney's fees, collection costs, and other related expenses incurred by CSAW in order to collect any money due under the payment terms of this agreement, plus interest and late fees, that is permitted by law, on all past due amounts.
- 6) Client indemnifies CSAW against any claim by any property owner, landlord, tenant, or any other party that the above signs may violate. This includes any agreements the client may have with said parties or where such signs are not properly authorized by the parties and where their authorization is required.
- 7) If, during the install, our work is delayed or obstructed due to the actions or inactions of the on-site contact, a waiting fee of \$100 per hour will be incurred for the duration of the delay.



marketing, signs, & print • brandconnectnc.com

# Estimate

NO: 87334

11917

Adam Miller  
 Franks Jewelery  
 202 N Main st  
 Graham NC  
 Phone: (336) 226-4553

Date: 12/31/25

CUSTOMER PO:

E-Mail franksjlry@gmail.com

Quantity	Description	Amount
1	removal + install of new projecting sign  -(1) 33" x 33" double sided illuminated round projecting sign with 60" projection  ---install included ---permitting fees tbd ---50% deposit required before permit is submitted	\$ 4,759.75
Sales Rep: Bobby Dunson Taken by: Bobby Dunson  Account Type: COD  <b>This estimate is valid until Jan 29, 2026</b> <b>50% Deposit Due on All Signage Orders</b>		SUBTOTAL \$ 4,759.75 TAX \$ 321.28 SHIPPING \$ 0.00 DEPOSITS \$ 0.00 TOTAL \$ 5,081.03 AMOUNT DUE \$ 5,081.03

Received By:	Date:	Number of Cartons:
--------------	-------	--------------------





marketing, signs, & print • brandconnectnc.com

# Estimate

NO: 87334

11917

Adam Miller  
Franks Jewelery  
202 N Main st  
Graham NC  
Phone: (336) 226-4553

Date: 1/21/26

CUSTOMER PO:

E-Mail franksjlry@gmail.com

Quantity	Description	Amount
1	removal + refurb of cabinet sign, and install of new projecting sign  -(1) 33" x 33" double sided illuminated round projecting sign with 60" projection  -(1) refurbish existing pan sign with LED retrofit  ---install included ---permitting fees tbd ---50% deposit required before permit is submitted	\$ 8,390.50
Sales Rep: Bobby Dunson Taken by: Bobby Dunson  Account Type: COD  <b>This estimate is valid until Jan 29, 2026</b> <b>50% Deposit Due on All Signage Orders</b>		SUBTOTAL \$ 8,390.50 TAX \$ 566.36 SHIPPING \$ 0.00 DEPOSITS \$ 0.00 TOTAL \$ 8,956.86 <b>AMOUNT DUE \$ 8,956.86</b>

Received By:	Date:	Number of Cartons:
--------------	-------	--------------------



**Appearance/Tree board  
Commission Calendar**

**January**

Ideas/goals for new year

---

**February**

- Arbor Day Planning/Discussion
  - Renee Russell – Business Owner Involvement
  - Appearance Award Advertising & Plan
- 

**March**

- Arbor Day – Follow Up
- 

**April**

- Residential/Business Appearance Nominations
  - Creek Week Cleanup (Spring)
- 

**May**

---

**June**

---

**July**

- Residential/Business Appearance Nominations
- 

**August**

- Downtown Decorations – Inventory & Spreadsheet
- 

**September**

- Establish Beautification Grant Advertising Plan
  - Downtown Decorations – Plan
- 

**October**

- Residential/Business Appearance Nominations
  - Creek Week Cleanup (Fall)
  - Downtown Decorations - Scheduling
- 

**November**

- Business Beautification Grants Hearing
- 

**December**

- Downtown Window Decorations
  - Residential/Business Appearance Nominations
- 

**Potential Meeting Dates 2026**

*February 2nd  
March 2nd  
April 6th  
May 4th  
June 1st  
July 6th  
August 3rd  
September 7th  
October 5th  
November 2nd  
December 7th*

Months with No meetings:  
May, June.

Carry over ideas from 2025:

- 
-

## Residential Appearance Award – Contact Protocol:

- Can we require the Nominator to submit photos of the Nominee's house?
- Make it known on application that we'll reach out to the winner for a photo op; State on the application that if they decline, we can use their submission photo for social media advertising.
  - o Omit address and other personal info from social media post.
- \*\*\*If the Nominator is appointing someone else, how can the Nominee prove consent regarding any application, photo, and social media post?
  - o Written consent letter attached to application (similar to property owner for grant applications)?
  - o Signature?
  - o Should we restrict applicants to only nominating themselves?

## Business Appearance Award:

- How should we handle the Business Appearance Award?
- Same process as prior years – the Commission votes to nominate businesses?
- Should we copy Residential Award process (citizens are free to nominate themselves or each other)?
- Coinciding with Residential Award (rolling submissions)?

## Other:

- Do we need to revise the website application each quarter in-line with the rolling submission schedule?
- Marketing strategies to encourage more submissions?

# Arbor Day- April 24, 2026

**Activities from 2025:** (see the "Arbor Day in Graham" webpage for details of each event at <https://www.cityofgraham.com/arbor-day-in-graham/>)

- [Arbor Day Art Contest](#) (Entries Accepted: March 17 – April 6, 2025) - *4 pieces of art submitted (4 of the 4 prizes distributed)*
- [Arbor Day Kindness Rock Hunt in Downtown Graham](#) (Dates: April 1 – 30, 2025, or while prizes last) - *5 rocks, 5 prizes (3 of the 5 prizes distributed)*
- [Going Bonkers for Botany at South Graham Park](#) (Date: Tuesday, April 21, 2025) - *2 registered (no one attended)*
- [Arbor Day in Graham's Tree Planting Ceremony at the Graham Recreation Center](#) (Date: Friday, April 25, 2025)
- Tree Resources were available on the "Arbor Day in Graham" website and shared on social media throughout the month

## New Activities for 2026:

- **NEW & TENTATIVE (IN PLANNING PHASE): Chill & Thrill: Park Pop-Up** (THEME: Tree BINGO) (Date: Monday, April 6, 2026, at 10am-12pm at Graham Regional Park) - **WORKING ON OBTAINING TREE SAPLING DONATIONS**
- **NEW & TENTATIVE (IN PLANNING PHASE): Leaves, Light & Lenses:** Phone Photography in the Parks (Date: TBD) - **IN CONTACT WITH A PHOTOGRAPHER TO LEAD THE PROGRAM**
- **NEW & TENTATIVE (IN PLANNING PHASE): ecoEXPLORE Scavenger Hunt:** Tree Themed (3 locations: Bill Cooke Park, Graham-Mebane Lake, South Graham Park) - **SCAVENGER HUNT WILL BE AVAILABLE ON SITE AND ON THE WEBSITE**
- [Arbor Day in Graham's Tree Planting Ceremony at Bill Cooke Park](#) (Date: Friday, April 24, 2026, at 10am-11am) - (located by the playground, Shelter 1, & Field #3) - **GRAHAM RECREATION & PARKS MENTORING PROGRAM AT NORTH GRAHAM ELEMENTARY • GRADES: 3, 4, 5 • 8-10 STUDENTS ATTENDING**
- Tree Resources available on the "Arbor Day in Graham" website and shared on social media throughout the month

## Ideas/Points from the Commission:

- Reach out to Schools to market games/competitions; How to effectively contact?
- Need to plan out donations from prizes.
- Any other ideas or concerns from the Commission?